

Pioneer

Operating Instructions | Mode d'emploi | Bedienungsanleitung |
Istruzioni per l'uso | Handleiding | Manual de instrucciones |
Инструкции по эксплуатации



Integrated Amplifier | Amplificateur Intégré |
Eingebauter Verstärker | Amplificatore Integrato |
Geïntegreerde versterker | Amplificador integrado |
Интегрированный усилитель

A-30-K/S

A-20-K/S

A-10-K/S

IMPORTANT



The lightning flash with arrowhead symbol, within an equilateral triangle, is intended to alert the user to the presence of uninsulated "dangerous voltage" within the product's enclosure that may be of sufficient magnitude to constitute a risk of electric shock to persons.



CAUTION:
TO PREVENT THE RISK OF ELECTRIC SHOCK, DO NOT REMOVE COVER (OR BACK). NO USER-SERVICEABLE PARTS INSIDE. REFER SERVICING TO QUALIFIED SERVICE PERSONNEL.



The exclamation point within an equilateral triangle is intended to alert the user to the presence of important operating and maintenance (servicing) instructions in the literature accompanying the appliance.

D3-4-2-1-1_A1_En

WARNING

This equipment is not waterproof. To prevent a fire or shock hazard, do not place any container filled with liquid near this equipment (such as a vase or flower pot) or expose it to dripping, splashing, rain or moisture.

D3-4-2-1-3_A1_En

WARNING

Before plugging in for the first time, read the following section carefully.

The voltage of the available power supply differs according to country or region. Be sure that the power supply voltage of the area where this unit will be used meets the required voltage (e.g., 230 V or 120 V) written on the rear panel.

D3-4-2-1-4*_A1_En

European model only

Information for users on collection and disposal of old equipment and used batteries

(Symbol for equipment)



These symbols on the products, packaging, and/or accompanying documents mean that used electrical and electronic products and batteries should not be mixed with general household waste.

For proper treatment, recovery and recycling of old products and used batteries, please take them to applicable collection points in accordance with your national legislation.

By disposing of these products and batteries correctly, you will help to save valuable resources and prevent any potential negative effects on human health and the environment which could otherwise arise from inappropriate waste handling.

For more information about collection and recycling of old products and batteries, please contact your local municipality, your waste disposal service or the point of sale where you purchased the items.

These symbols are only valid in the European Union.

For countries outside the European Union:

If you wish to discard these items, please contact your local authorities or dealer and ask for the correct method of disposal.

(Symbol examples for batteries)



Pb

K058a_A1_En

WARNING

To prevent a fire hazard, do not place any naked flame sources (such as a lighted candle) on the equipment.

D3-4-2-1-7a_A1_En

VENTILATION CAUTION

When installing this unit, make sure to leave space around the unit for ventilation to improve heat radiation (at least 30 cm at top, 10 cm at rear, and 10 cm at each side).

WARNING

Slots and openings in the cabinet are provided for ventilation to ensure reliable operation of the product, and to protect it from overheating. To prevent fire hazard, the openings should never be blocked or covered with items (such as newspapers, table-cloths, curtains) or by operating the equipment on thick carpet or a bed.

D3-4-2-1-7b*_A1_En

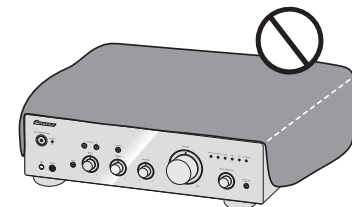

Operating Environment

Operating environment temperature and humidity:
+5 °C to +35 °C (+41 °F to +95 °F); less than 85 %RH
(cooling vents not blocked)

Do not install this unit in a poorly ventilated area, or in locations exposed to high humidity or direct sunlight (or strong artificial light)

D3-4-2-1-7c*_A1_En

If the AC plug of this unit does not match the AC outlet you want to use, the plug must be removed and appropriate one fitted. Replacement and mounting of an AC plug on the power supply cord of this unit should be performed only by qualified service personnel. If connected to an AC outlet, the cut-off plug can cause severe electrical shock. Make sure it is properly disposed of after removal. The equipment should be disconnected by removing the mains plug from the wall socket when left unused for a long period of time (for example, when on vacation).

D3-4-2-2-1a_A1_En

CAUTION

The **⏻/I STANDBY/ON** switch on this unit will not completely shut off all power from the AC outlet. Since the power cord serves as the main disconnect device for the unit, you will need to unplug it from the AC outlet to shut down all power. Therefore, make sure the unit has been installed so that the power cord can be easily unplugged from the AC outlet in case of an accident. To avoid fire hazard, the power cord should also be unplugged from the AC outlet when left unused for a long period of time (for example, when on vacation).

D3-4-2-2-2a*_A1_En

This product is for general household purposes. Any failure due to use for other than household purposes (such as long-term use for business purposes in a restaurant or use in a car or ship) and which requires repair will be charged for even during the warranty period.

K041_A1_En

POWER-CORD CAUTION

Handle the power cord by the plug. Do not pull out the plug by tugging the cord and never touch the power cord when your hands are wet as this could cause a short circuit or electric shock. Do not place the unit, a piece of furniture, etc., on the power cord, or pinch the cord. Never make a knot in the cord or tie it with other cords. The power cords should be routed such that they are not likely to be stepped on. A damaged power cord can cause a fire or give you an electrical shock. Check the power cord once in a while. When you find it damaged, ask your nearest PIONEER authorized service center or your dealer for a replacement.

S002*_A1_En

(A-30 only)



CAUTION: HOT SURFACE. DO NOT TOUCH.

The top surface over the internal heatsink may become hot when operating this product continuously.

Thank you for buying this Pioneer product.

Please read through these operating instructions so that you will know how to operate your model properly. After you have finished reading the instructions, put them in a safe place for future reference.

Contents

01 Before you start

What's in the box	4
Loading the batteries in the remote control (Except A-10)	4
Using the remote control	4
Installing the amplifier	4

02 Connecting up

Making cable connections	5
About "Bi-wiring"	5
Connecting speaker cables	6
Connecting audio cables	6
Using centralized control with other Pioneer components (Except A-10)	6
Plugging in	6

03 Controls and displays

Front panel	7
Rear panel	8
Remote control (Except A-10)	9

04 Operation

Playback	10
Set the power to Standby	10
When using the unit as a power amplifier (A-30 only)	10
Making an audio recording	11
To set for automatic standby status (Auto Power Down)	11
Restoring all the settings to the factory default settings	11

05 Additional information

Troubleshooting	12
Cleaning the unit	12
Specifications	13

Chapter 1: Before you start

What's in the box

Please confirm that the following accessories are in the box when you open it.

- Remote control (Except A-10)
- AAA/IEC R03 dry cell batteries x2 (Except A-10)
- Power cord
- Warranty card
- Operating instructions (This document)



Note

- Illustrations featured in the Operating Instructions may have been modified or simplified for ease of explanation, and may therefore differ from the actual product appearance.
- The illustrations used here are mainly of the A-30.

Loading the batteries in the remote control (Except A-10)

1 Open the rear lid.

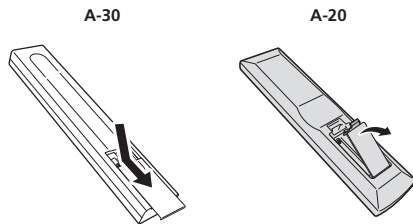

2 Insert the new batteries, matching the polarities as indicated inside the case.

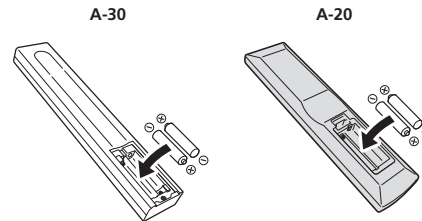

3 Close the rear lid.

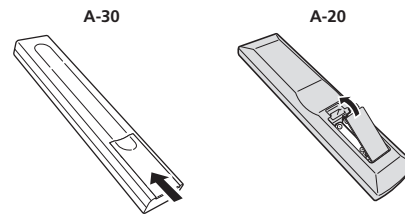

The batteries included with the unit have been provided to allow you check product operation and may not last long. We recommend using alkaline batteries that have a longer life.

⚠ WARNING

- Do not use or store batteries in direct sunlight or other excessively hot place, such as inside a car or near a heater. This can cause batteries to leak, overheat, explode or catch fire. It can also reduce the life or performance of batteries.

⚠ Caution

Incorrect use of batteries may result in such hazards as leakage and bursting. Observe the following precautions:

- When inserting the batteries, make sure not to damage the springs on the battery's ⊖ terminals.

- Do not use any batteries other than the ones specified. Also, do not use a new battery together with an old one.
- When loading the batteries into the remote control, set them in the proper direction, as indicated by the polarity marks (+ and ⊖).
- Do not heat batteries, disassemble them, or throw them into flames or water.
- Batteries may have different voltages, even if they are the same size and shape. Do not use different types of batteries together.
- To prevent leakage of battery fluid, remove the batteries if you do not plan to use the remote control for a long period of time (1 month or more). If the fluid should leak, wipe it carefully off the inside of the case, then insert new batteries. If a battery should leak and the fluid should get on your skin, flush it off with large quantities of water.
- When disposing of used batteries, please comply with governmental regulations or environmental public institution's rules that apply in your country/area.

Using the remote control

The remote has a range of about 7 m at an angle of about 30° from the remote sensor.

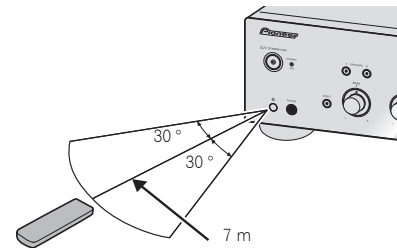

Keep in mind the following when using the remote control:

- Make sure that there are no obstacles between the remote and the remote sensor on the unit.
- Remote operation may become unreliable if strong sunlight or fluorescent light is shining on the unit's remote sensor.
- Remote controllers for different devices can interfere with each other. Avoid using remotes for other equipment located close to this unit.
- Replace the batteries when you notice a fall off in the operating range of the remote.

Installing the amplifier

When installing this unit, make sure to put it on a level and stable surface.

- Don't install it on the following places:
 - on a color TV (the screen may distort)
 - near a cassette deck (or close to a device that gives off a magnetic field). This may interfere with the sound.
 - in direct sunlight
 - in damp or wet areas
 - in extremely hot or cold areas
 - in places where there is vibration or other movement
 - in places that are very dusty
 - in places that have hot fumes or oils (such as a kitchen)
- Do not mount the unit on a sofa or other object or material with absorbent qualities, since sound quality may be adversely affected.

Chapter 2: Connecting up

Making cable connections

Caution

- Before making or changing the connections, switch off the power and disconnect the power cord from the AC outlet.
- Connect the power cord after all the connections between devices have been completed.

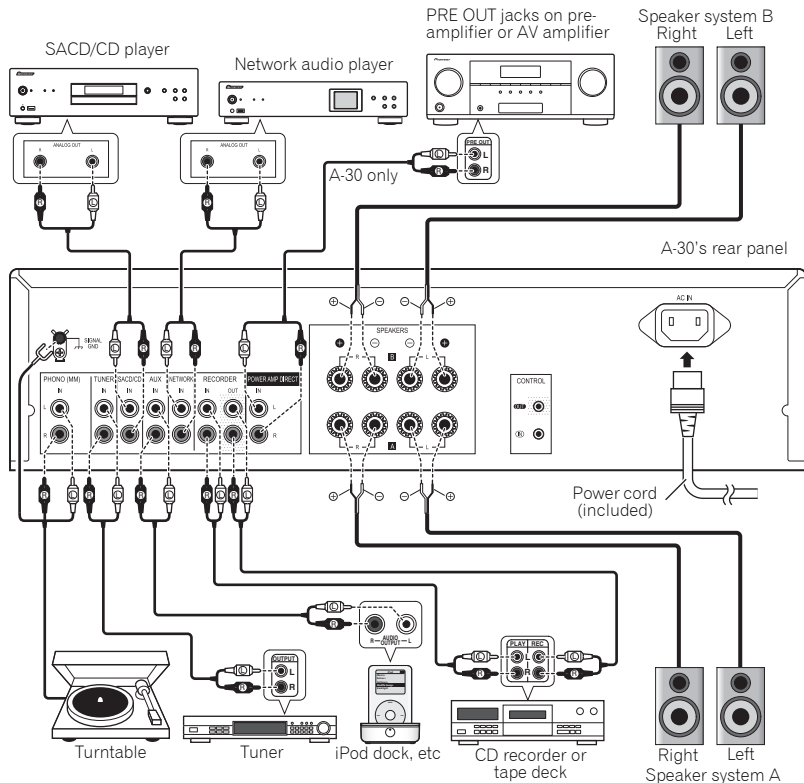

Caution

- The **SIGNAL GND** terminal is provided to reduce noise when connecting the unit to components such as an analog turntable.
- Do not connect the **PHONO (MM)** terminals to any component other than a turntable; also, do not connect to a turntable equipped with built-in equalizer. An excessively high sound output may be produced, resulting in damage to your speakers or other devices.
- The unit's **PHONO (MM)** terminals are designed to be used with turntables equipped with MM (moving-magnet) type cartridges. Turntables equipped with MC (moving-coil) cartridges cannot be used.
- Make sure not to bend the cables over the top of this unit (as shown in the illustration). If this happens, the magnetic field produced by the transformers in this unit may cause a humming noise from the speakers.

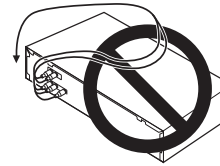

- The unit's **POWER AMP DIRECT** terminals should never be connected to any other component's connectors except PRE-AMP OUT.
- If your turntable has a grounding wire, secure it to the ground terminal on this amplifier.

Note

- When connecting a tape cassette deck, playback noise may be heard, depending on the installation location. This noise is caused by leakage flux from the amplifier's transformer. In this event, change the installation location, or move the deck farther from the amplifier.
- iPod is a trademark of Apple Inc., registered in the U.S. and other countries.

About "Bi-wiring"

This unit can be used with speakers that support bi-wiring. Be sure to connect the high-frequency and low-frequency connections correctly.

- During playback, be sure that both the **SPEAKERS A** button and **SPEAKERS B** button are set to ON (page 7).

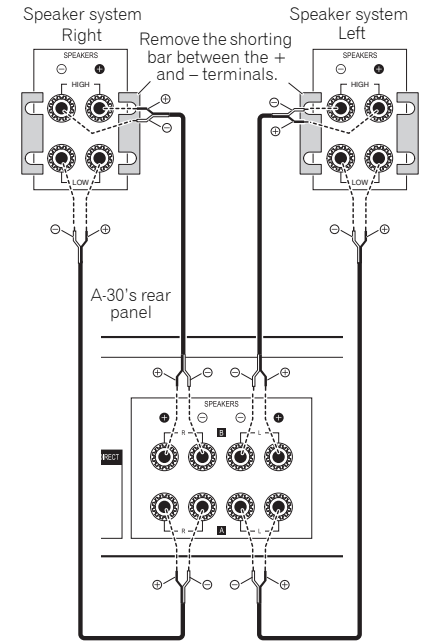

Caution

- When using bi-wiring to connect speakers, avoid adverse effects on the amplifier by being sure to remove the HIGH and LOW short bars provided with the speakers. For detailed information, consult the instructions provided with the speakers.
- When using speakers with removable network circuits, note that if the network is removed, no effect will be produced and damage may be caused to the speaker.
- Another method of connection is to connect the **SPEAKERS A** terminals to HIGH and the **SPEAKERS B** terminals to LOW (reverse that shown in the illustration).

Connecting speaker cables

- 1 Twist the cable cores.
- 2 Loosen the nut on the **SPEAKERS** terminal, and insert the speaker cable into the exposed hole in the terminal shaft.
- 3 Retighten the terminal nut.

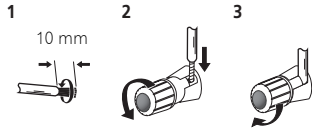

⚠ Caution

- When using only one set of speaker terminals (**SPEAKERS A** or **SPEAKERS B**), or when utilizing bi-wiring connections, the speaker used should have a nominal impedance between 4 Ω and 16 Ω. When using both sets of terminals, the connected speakers should have nominal impedance between 8 Ω and 32 Ω. Consult the instructions accompanying your speakers for details regarding the impedance value.
- Make sure the positive and negative (+/-) terminals on the amplifier match those on the speakers.
- These speaker terminals carry **HAZARDOUS live voltage**. To prevent the risk of electric shock when connecting or disconnecting the speaker cables, disconnect the power cord before touching any uninsulated parts.
- Make sure that all the bare speaker wire is twisted together and inserted fully into the speaker terminal. If any of the bare speaker wire touches the back panel it may cause the power to cut off as a safety measure.

Connecting audio cables

Connect the white plug to the left (L) jack, and the red plug to the right (R) jack. Be sure to insert the plugs fully into the jacks.

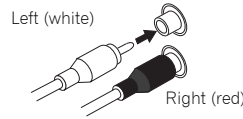

Using centralized control with other Pioneer components (Except A-10)

Multiple Pioneer components equipped with **CONTROL IN/OUT** jacks can be connected to the A-30/A-20 unit, allowing centralized control of the components via the remote sensor on the A-30/A-20. This also allows remote control of components not equipped with a remote sensor, or installed in places where the component's remote sensor cannot be accessed.

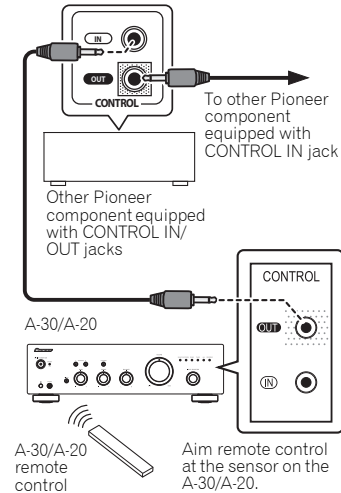

📌 Note

- For connections use a commercially available monaural miniplug cord (without resistor).
- When connecting the **CONTROL IN/OUT** jacks, commercially available audio cords must also be used to make analog connections. Merely connecting the **CONTROL IN/OUT** jacks alone will not allow proper system control.
- When a control cord is connected to the A-30/A-20's **CONTROL IN** jack, the unit cannot be controlled by pointing the remote control at the A-30/A-20 (the remote sensor is automatically disabled).

Plugging in

👁 Important

- When going on a trip or otherwise not using the unit for an extended period, always disconnect the power cord from its outlet. Note that various internal settings will not be lost even if the power cord is disconnected from its outlet for an extended time.
- If it is necessary to detach the power cord, first be sure to press the **⏻/STANDBY/ON** button on the front panel of the unit so the A-30/A-20 is turned OFF or the A-10 is in standby mode before detaching the cord.

⚠ Caution

- The use of a power cord other than the one provided will invalidate the warranty, since Pioneer will not be responsible for any damage incurred. (The power cord provided with the model A-30 has a rated current capacity of 10 A, while the cord provided with the A-20/A-10 has a rated current capacity of 2.5 A.)
- Do not use any power cord other than the one supplied with this unit.
- Do not use the supplied power cord for any purpose other than that described below.

After you've finished making all connections, plug the unit into an AC outlet.

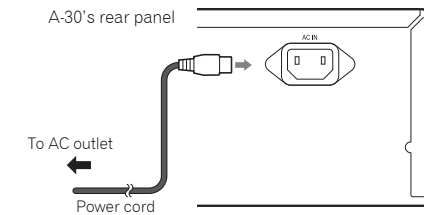

- 1 Plug the supplied power cord into the **AC IN** socket on the rear panel of the unit.
- 2 Plug the other end into an AC outlet.

Chapter 3:

Controls and displays

Front panel

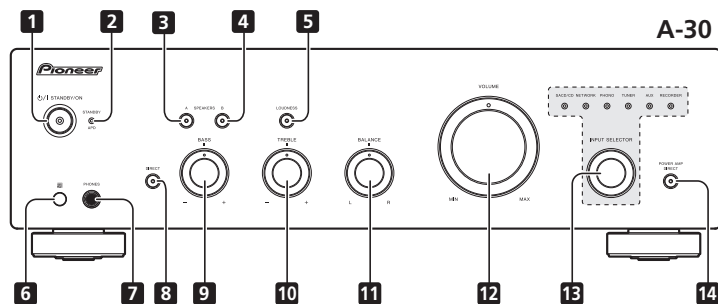

1 **⏻/I STANDBY/ON**

Switches the amplifier between off and on. When power is turned on, the power indicator in the center of the button will light.

- On the A-10 model, this switches the amplifier between standby and on.

2 **STANDBY/APD indicator**

When power is set to standby, the indicator lights red. When the Auto Power Down (APD) function is on, the indicator lights green (page 11).

3 **SPEAKERS A button/indicator**

Use this button to listen to the speaker system connected to **SPEAKERS A** terminals.

On : The indicator lights. Sound is heard from the speaker system. (Sound will also be produced from the **PHONES** jack.)

Off : The indicator goes off. No sound is heard from the speaker system. Set to this position when listening with headphones.

4 **SPEAKERS B button/indicator**

Use this button to listen to the speaker system connected to **SPEAKERS B** terminals.

On : The indicator lights. Sound is heard from the speaker system. (Sound will also be produced from the **PHONES** jack.)

Off : The indicator goes off. No sound is heard from the speaker system. Set to this position when listening with headphones.

5 **LOUDNESS button/indicator**

Use when listening at low volume levels.

On : The indicator lights: Boosts low and high frequencies to give added punch to playback even at a low volume level.

Off : The indicator goes off: Should normally be left in this position.

- This button does not operate when the **DIRECT** button is in the on position.
- When sound volume is raised, the amount of change produced by the **LOUDNESS** circuit is reduced.

6 **Remote sensor (Except A-10)**

Receives the signals from the remote control (page 4).

7 **PHONES jack**

Use to connect headphones. No sound is produced when the **POWER AMP DIRECT** button is ON.

8 **DIRECT button/indicator**

On : The indicator lights: When this button is set to ON, sound signals are output directly, without being passed through the various adjustment circuits (**BASS, TREBLE, BALANCE, LOUDNESS**). This allows reproduction of the signals with greater fidelity, but it disables any settings made with the **BASS, TREBLE, BALANCE** or **LOUDNESS** controls.

Off : The indicator goes off: The signal passes through the various frequency adjusting circuits. When the indicator is OFF, adjustments can be made with the **BASS, TREBLE, BALANCE, and LOUDNESS** controls.

9 **BASS tone control**

Use to adjust the low-frequency tone. The center position is the flat (normal) position. When turned to the right, low-frequency tones are emphasized; when turned to the left, low-frequency tones are de-emphasized.

- This button does not operate when the **DIRECT** button is in the on position.

10 **TREBLE tone control**

Use to adjust the high-frequency tone. The center position is the flat (normal) position. When turned to the right, high-frequency tones are emphasized; when turned to the left, high-frequency tones are de-emphasized.

- This button does not operate when the **DIRECT** button is in the on position.

11 **BALANCE control**

Should normally be left in the center position. Adjust balance if the sound is louder from one of the speakers. If the right side is louder, turn toward the L (left) position and if the left side is louder, turn toward the R (right) position.

- This button does not operate when the **DIRECT** button is in the on position.

12 **VOLUME control**

Use to adjust the volume level. (Also allows adjustment of the headphone sound volume.)

13 **INPUT SELECTOR knob/indicators**

Turn the knob clockwise or counterclockwise so that the indicator lights for your desired input source. Turning the knob clockwise causes the lit indicator to right. Turning counterclockwise causes it to left. When the remote control's **MUTE** button is pressed to mute the sound, the indicator for the input source selected with the **INPUT SELECTOR** knob flashes.

14 **POWER AMP DIRECT button/indicator (A-30 only)**

Press this button when the A-30 is to be used as a power amplifier (page 10).

Rear panel

See pages 5-6 for details regarding connections.

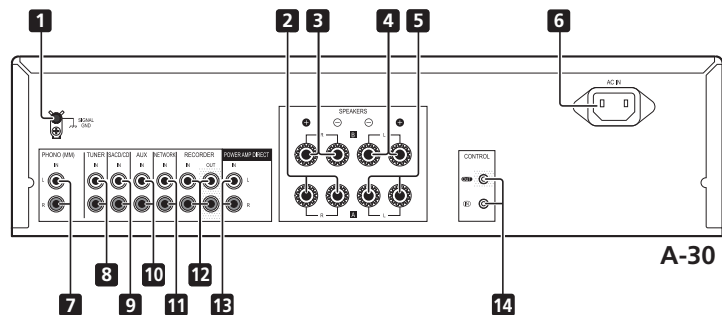

1 GND (Turntable ground) terminal

This ground terminal is designed to help reduce noise when a turntable is connected. It is not a safety ground.

2 SPEAKERS A terminals (Right channel)

3 SPEAKERS B terminals (Right channel)

4 SPEAKERS B terminals (Left channel)

5 SPEAKERS A terminals (Left channel)

6 AC IN jack

Connect power cord to here and an AC wall socket.

7 PHONO (MM) IN terminals

8 TUNER IN terminals

9 SACD/CD IN terminals

10 AUX IN terminals

11 NETWORK IN terminals

12 RECORDER IN/OUT terminals

13 POWER AMP DIRECT IN terminals (A-30 only)

When using the A-30 as a power amplifier, connect the pre-amplifier here (page 10).

14 CONTROL IN/OUT jack (Except A-10)

Remote control (Except A-10)

A-30

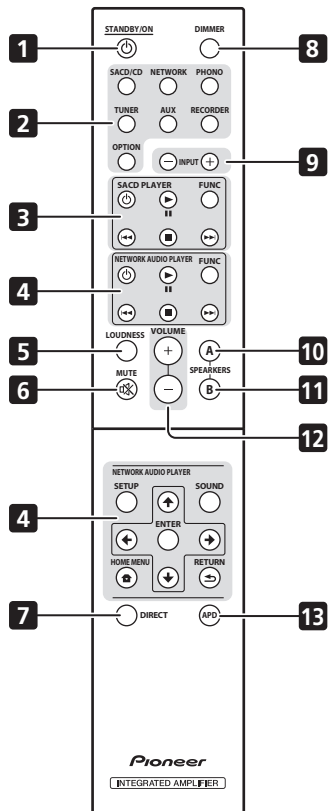

A-20

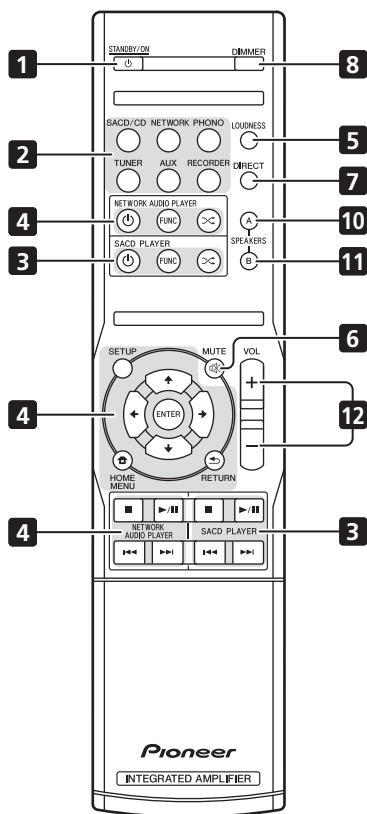

1 **STANDBY/ON**

Switches the amplifier between standby and on.

2 **Input selector buttons**

Press to select an input source. These select the component connected to the corresponding input on the rear panel.

- When the A-30 is connected, the **OPTION** button is disabled.

3 **SACD PLAYER control buttons**

Use to control Pioneer SACD player. (Cannot be used to perform playback/pause on the PD-D6/PD-D6MK2/PD-D9/PD-D9MK2 models.)

4 **NETWORK AUDIO PLAYER control buttons**

Use to control Pioneer network audio player.

5 **LOUDNESS**

Use to set the loudness circuit ON/OFF (page 7).

6 **MUTE**

Mutes/unmutes the sound.

7 **DIRECT**

Press to access Direct listening (page 7).

8 **DIMMER**

This button allows the illumination of the unit's front panel indicators to be set in three levels (does not affect the **STANDBY** indicator).

9 **INPUT +/-**

Use to change the input source. The source changes as below.

SACD/CD ↔ NETWORK ↔ PHONO ↔ TUNER ↔ AUX ↔ RECORDER ↔ Return to the beginning.

10 **SPEAKERS A button/indicator**

Use this button to listen to the speaker system connected to **SPEAKERS A** terminals.

11 **SPEAKERS B button/indicator**

Use this button to listen to the speaker system connected to **SPEAKERS B** terminals.

12 **VOLUME +/-**

Use to set the listening volume.

13 **APD**

Use to set the Auto Power Down function to ON/OFF (page 11).

Chapter 4: Operation

Playback

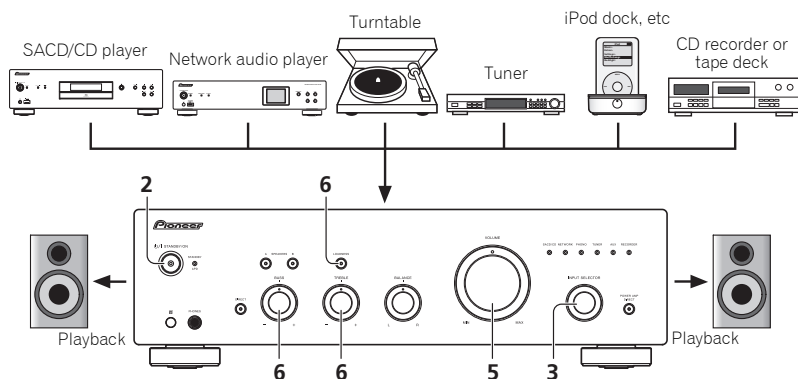

1 Turn on the power of the playback component.

2 Turn power ON to the unit.

- If the unit is in the standby mode, press the remote control's **STANDBY/ON** button.



3 Select the source you want to playback.

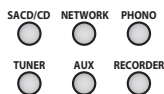

Select the playback component.

- When using the A-30's remote control, the **INPUT +/-** button can be used to select the component.
- When using the front panel controls, rotate the **INPUT SELECTOR** knob.

4 Start playback of the component you selected in step 1.

5 Adjust playback volume with VOLUME control.



6 Adjust the tone to your preference using the BASS and TREBLE controls, and LOUDNESS button.

If the **DIRECT** button has been set to ON, these controls are disabled.

Set the power to Standby

- Press the remote control's **STANDBY/ON** button.



The next time you wish to turn on the power, press the remote control's **STANDBY/ON** button.

- In the case of the A-30/A-20, If the front panel's **STANDBY/ON** button is pressed, the power will be turned off. In this case, if the power is off, pressing the remote control's **STANDBY/ON** button will not turn on the power. To turn on the power again, press the front panel's **STANDBY/ON** button.

Note

- If the power cord is disconnected when the unit is in the standby mode the unit will turn off, but when the cord is then reconnected, the unit will not automatically turn on. After reconnecting the power cord, press the remote control's **STANDBY/ON** button to turn the power on.

When using the unit as a power amplifier (A-30 only)

When a pre-amplifier is connected to the unit's **POWER AMP DIRECT** terminals, the unit can be used as a power amplifier.

- Press the **POWER AMP DIRECT** button on the front panel of the unit.

The **POWER AMP DIRECT** indicator will light.

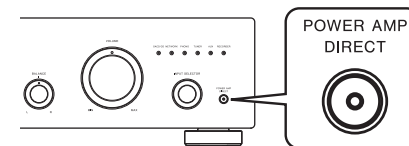

Caution

- When the **POWER AMP DIRECT** indicator is lighted, operations change as follows:
 - The unit's front-panel **VOLUME**, **BASS**, **TREBLE**, and **BALANCE** controls are disabled. These adjustments are controlled by the component connected to the unit's **POWER AMP DIRECT** terminals.
 - When the **POWER AMP DIRECT** indicator is lighted, sound volume from the A-30 will automatically be fixed at its maximum output. When using this unit as a power amplifier, check the output level of the component connected to the **POWER AMP DIRECT** terminals and set it to a low level as appropriate before turning on the **POWER AMP DIRECT** indicator. If the sound volume of the component connected to the **POWER AMP DIRECT** terminals is initially set to a high output level, loud sound may suddenly be output when the **POWER AMP DIRECT** indicator lights.
 - Sound is not produced from the **PHONES** jack and **RECORDER OUT** terminals.
- For more information, consult the operating instructions for the component connected to the A-30's **POWER AMP DIRECT** terminals.

Making an audio recording

You can make an audio recording from any audio source connected to the amplifier.

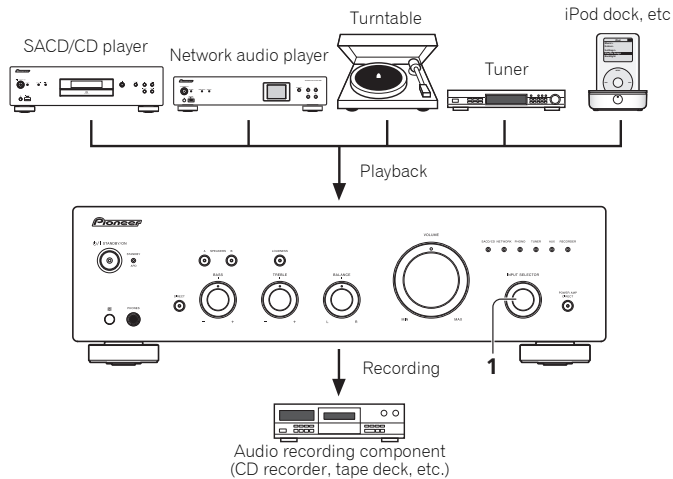

1 Select the source you want to record.

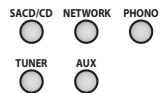

2 Start recording, then start playback of the source component.

To set for automatic standby status (Auto Power Down)

When this condition is set, if no input signal is detected for 30 minutes, the unit will automatically enter standby status.

1 If the unit's power is ON, hold the unit's front-panel **DIRECT** button and **LOUDNESS** button depressed simultaneously for three seconds.

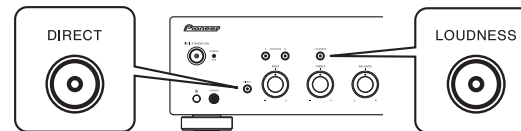

When this condition is set to ON, the **STANDBY/APD** indicator on the unit's front panel will light green. Press the buttons again to disable the setting.

- This condition can also be set by means of the **APD** button on the A-30's remote control.
- The factory default setting is ON.

Note

- Depending on the device connected, excessive noise produced by the device may be interpreted as an audio signal, thus preventing the Automatic Power-Down function from operating.

Restoring all the settings to the factory default settings

1 When power is in standby mode, hold the front-panel's **DIRECT** button and **SPEAKERS A** button depressed simultaneously for five seconds.

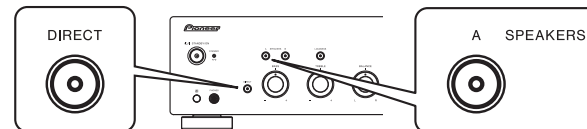

2 Turn power ON to the unit.

Chapter 5:

Additional information

Troubleshooting

Incorrect operations are often mistaken for trouble and malfunctions. If you think that there is something wrong with this component, check the points below. Sometimes the trouble may lie in another component. Investigate the other components and electrical appliances being used. If the trouble cannot be rectified even after exercising the checks listed below, ask your nearest Pioneer authorized service center or your dealer to carry out repair work.

- If the unit does not operate normally due to external effects such as static electricity disconnect the power plug from the outlet and insert again to return to normal operating conditions.

Problem	Remedy
The power does not turn on.	<ul style="list-style-type: none"> • Is the power plug disconnected from the power outlet? Connect the power plug correctly to its outlet (page 6). • Is the power cord disconnected from the AC IN connector? Connect the power cord correctly (page 6).
Power turns off.	<ul style="list-style-type: none"> • Is the Auto Power Down function turned ON? If you do not want the power to turn off automatically, disable the Auto Power Down function (page 11).
During playback, sound stops, and the STANDBY/APD indicator flashes red at about 1 second intervals.	<ul style="list-style-type: none"> • The unit's internal temperature has risen and the safety circuit has operated. <ul style="list-style-type: none"> - Turn power OFF, and allow the unit to cool before turning the power ON again. - Install the unit in a location with better ventilation. - Confirm that the unit is installed correctly; if the unit is turned on again without being allowed to cool, the same symptoms may appear (page 4).
During playback, sound stops, and the STANDBY/APD indicator flashes red at about 2 second intervals.	<ul style="list-style-type: none"> • Are you using speakers with impedance values not supported by this unit? Confirm the speaker's nominal impedance value (page 6). • Are any speaker cables loose from the SPEAKERS terminals and touching other wires or the surface of the rear panel? Disconnect the power cord and reconnect the speaker cables correctly (page 6).
When power is turned on, the STANDBY/APD indicator flashes at irregular intervals.	<ul style="list-style-type: none"> • The unit's circuitry is damaged. Disconnect the power cord and consult your dealer or nearest Pioneer authorized service center.
No sound is output when a function is selected.	<ul style="list-style-type: none"> • A connection cable is disconnected or connected improperly. Check your connections (page 5). • Connectors or pin plugs on a cable are dirty. Wipe off any dirt from connectors and pin plugs. • Confirm that the unit's input selector is set to the desired playback component. Set selector correctly (page 10). • In the case of the A-30/A-20, press MUTE on the remote control to turn muting off (page 9).
No sound from one speaker.	<ul style="list-style-type: none"> • Are the connection cables or speaker cables disconnected on one side? Reconnect securely (page 5).

Problem	Remedy
Can't operate the remote control.	<ul style="list-style-type: none"> • Replace the battery (page 4). • Operate within 7 m, 30° of the remote sensor on the front panel (page 4). • Remove the obstacle or operate from another position. • Avoid exposing the remote sensor on the front panel to direct light. • Is the control cord for one component connected improperly? Confirm correct connections (page 6).
Can't change input source on A-30.	<ul style="list-style-type: none"> • Check whether POWER AMP DIRECT function is ON. If so, press the front panel's POWER AMP DIRECT button to turn the function OFF (page 10).

Cleaning the unit

- Use a polishing cloth or dry cloth to wipe off dust and dirt.
- When the surface is dirty, wipe with a soft cloth dipped in some neutral cleanser diluted five or six times with water, and wrung out well, and then wipe again with a dry cloth. Do not use furniture wax or cleansers.
- Never use thinners, benzene, insecticide sprays or other chemicals on or near this unit, since these will corrode the surface.

Specifications

Amplifier section

Power output specification is for when power supply is 230 V.

- Continuous power output (both channels driven at 20 Hz to 20 kHz)**

A-30	70 W + 70 W
A-20, A-10	50 W + 50 W (THD 0.1 %, 4 Ω)
A-30	40 W + 40 W
A-20, A-10	30 W + 30 W (THD 0.05 %, 8 Ω)

Audio section

- Input (Sensitivity/Impedance)**

SACD/CD, NETWORK, TUNER, AUX, RECORDER	200 mV/50 kΩ
POWER AMP DIRECT (A-30 only)	1 V/10 kΩ
PHONO (MM)	2.8 mV/50 kΩ

- Output (Level/Impedance)**

RECORDER OUT	200 mV/2.2 kΩ
PHONES	250 mV/32 Ω

- Frequency response**

SACD/CD, NETWORK, TUNER, AUX, RECORDER	.5 Hz to 100 kHz ± 0.5 dB*
PHONO (MM)	.20 Hz to 20 kHz ± 0.5 dB*

* Measured with DIRECT button switched on.

- Tone control**

(When VOLUME is set to -30 dB)

Bass	± 10 dB (100 Hz)
Treble	± 10 dB (10 kHz)

- Signal-to-Noise Ratio (IHF SHORTED, A-NETWORK)**

SACD/CD, NETWORK, TUNER, AUX, RECORDER	105 dB*
PHONO (MM, 2.8 mV input)	77 dB*

* Measured with DIRECT button switched on.

- Speaker load impedance**

A, B	4 Ω to 16 Ω
A+B	8 Ω to 32 Ω
Bi-wiring	4 Ω to 16 Ω

Miscellaneous

Power requirements	AC 220 V to 230 V, 50 Hz
Power consumption	
A-30	175 W
A-20/A-10	135 W
In standby	0.3 W
Dimensions	
	435 mm (W) x 128 mm (H) x 360 mm (D)
Weight (without package)	
A-30	7.9 kg
A-20	7.2 kg
A-10	6.7 kg

Accessories

Remote control (Except A-10)	1
AAA/IEC R03 dry cell batteries (Except A-10)	2
Power cord	
Warranty card	
Operating instructions (This document)	



Note

- Specifications and the design are subject to possible modifications without notice, due to improvements.
- Corporation and product names mentioned herein are trademarks or registered trademarks of the respective corporations.